

環型近接開關-FSCA

型號：FSCA 環型近接開關

Characteristic/ 特點：

- 適合檢測通過的微小金屬
- 連接方式：線纜輸出
- 配有輸出信號延時功能



Dimensions/ 尺寸圖：

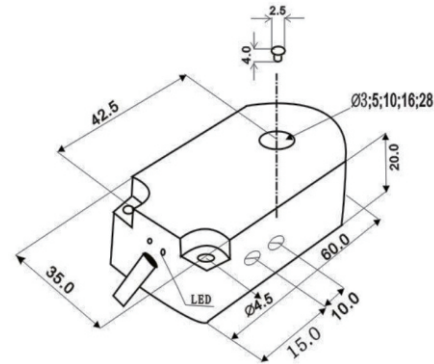
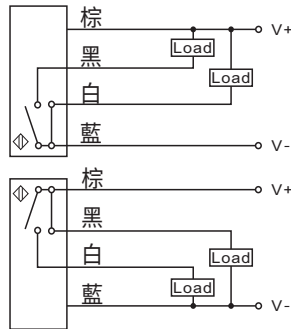

Specifications/ 規格表：

Model / 型號	NPN N.O./N.C.	FSCA03-N	FSCA05-N	FSCA10-N	FSCA16-N	FSCA28-N
	PNP N.O./N.C.	FSCA03-P	FSCA05-P	FSCA10-P	FSCA16-P	FSCA28-P
Sensing surface / 檢測方向	隔離型					
Diameter of bore / 內孔直徑	3mm 5mm 10mm 16mm 28mm					
Minimum sensing object / 最小檢測物	0.3mm 0.5mm 1mm 2mm 3mm					
Sensing distance / 檢出距離	20mm					
Induction frequency / 感應頻率	2KHZ					
Hysteresis / 遲滯	<15%(Sr)					
Repeated accuracy / 重複精度	<2.0%(Sr)					
Delay function / 延時功能	延時範圍0~100ms					
Operating voltage / 工作電壓	10~30VDC					
Voltage drop / 電壓降	<1.5V					
Output current / 輸出電流	≤200mA					
Leakage current / 漏電流	<0.01mA					
Operating temperature / 工作溫度範圍	-25°C~+70°C					
The temperature drift / 溫度飄移	±10%(Sr)					
Protection degree / 防水等級	Ip67					
Wiring method / 出線方式	Ø4*2M*3wires					
Housing material / 外殼材料	PBT					
protection circuit / 保護電路	極性保護/短路保護/暫態保護					
Weight / 重量	約47g					